

## Floodlight BS Spare parts

Valid up to the year of construction 1994

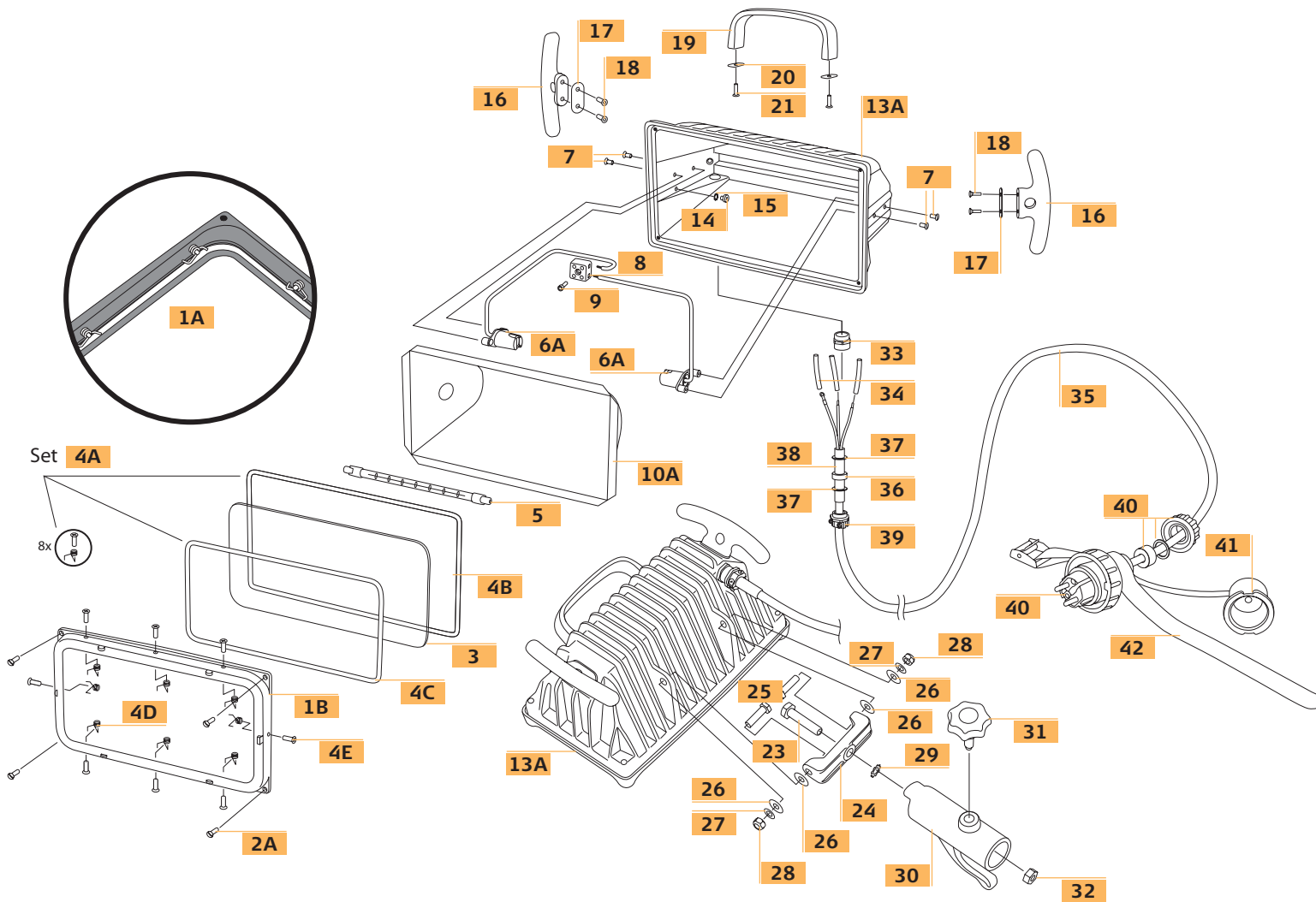

**Karl Meister GmbH**  
Lighting Devices

**after-sales service:**  
Markwiesenstrasse 30  
72770 Reutlingen  
phone +49 (0)7121/566012  
fax +49 (0)7121/566013  
www.karl-meister.de  
info@karl-meister.de

**customer advisory + sale:**  
Markwiesenstrasse 30  
72770 Reutlingen  
phone +49 (0)7121/561800  
fax +49 (0)7121/566013  
vertrieb@karl-meister.de

IMAGE	ORDER NO.	DESIGNATION	DIMENSIONS	UNITS
1A	135	Frame, fully assembled, comprising 1B, 4A, 3	272 x 154 aluminium	
1B	136	Frame alone	272 x 154 aluminium	1
2A	136 A	Fastening screws for frame	Cross-slit M4 x 16 A2 raised countersunk head screw	4
3	130	Glass pane	258 x 132 x 3.3	1
4A	148	Sealing set, comprising 4A, 4B, 4C, 4D	5.5mm x 785 mm	
4B	AVAILABLE AS SEALING SET ONLY, ART. NO. 148	Silicone seal	5.5 mm x 785 mm	1
4C		Silicone seal	4.0 mm x 732 mm	1
4D		Compression spring	Ø 3.5	8
4E		Compression spring screw	Cross-slit M3 x10 raised countersunk head screws	8
5	120, 121, 125	Lamp	230 V/500 W -/1000 W -/750 watts, overall length:190mm	1
6A	155	Glow stick holder with power cable and terminal	39 x 35 x Ø 20 with 8 x Ø8 aluminium stud	2
7	154 A	Fastening screw for glow-stick holder	Cylindrical screw, with hexagon socket, DIN 912 quality, 8.8 M3 x 10	4
8	154 B	Terminal block, porcelain	20 x 20 x 15 double terminal with central fixture	1
9	154 C	Fastening screws for terminal block	DIN 7991-quality 10.9 M 4 x 16 cylindrical screws with hexagon sockets	1
10A	133	Reflector	253 x 143 x 100	1
13A	171	Lamp housing	282 x 163 x 124 aluminium	1
14	170 C	Fastening screw for earth connection	Cross-slit DIN 7985 M 4 x 6 cheese-head countersunk screw	1
15	170 D	Toothed washer for earth connection	A2 DIN 6797 toothed washer, galvanised M4	1
16	139	Aluminium lateral grip	130 x 38 x 17	2
17	139 A	Rubber seal for lateral grips	37 x 17 x 1	2
18	139 B	Fastening screws for lateral grips	DIN 7991-quality 10.9 M 4x12 countersunk screw with hexagon socket	4
19	138	Aluminium carrying handle	129 x 50 x 28	1
20	138 A	Rubber seal for carrying handle	30 x 9 x 1	2
21	138 B	Fastening screws for carrying handle	DIN 7991-quality 10.9 M 4x16 countersunk screw with hexagon socket	2
23	140 A	Fastening screw for attachment piece	Hexagonal screw, quality 4.6 galvanised DIN 933, M10 x 45	1
24	141	Aluminium articulation piece	92 x 24 x 32	1
25	141 A	Fastening screw for articulation piece	Hexagonal screw, quality 8.8 galvanised DIN 933, M8 x 25	2
26	141 B	Washer for articulation piece	8.4 x 20 x 1.5, galvanised steel	4
27	141 C	Spring-lock washer for articulation piece	Ridged DIN 137 M8 spring-lock washer	2
28	141 D	Nut for articulation piece	DIN 982 M8 hexagonal nut, galvanised, self-locking	2
29	140 B	Toothed washer for attachment piece	M10 toothed washer	1
30	140	Aluminium attachment piece	130 x 105 x Ø 40	1
31	140 C	Star screw	M10 x 30 galvanised	1
32	140 D	Fastening nut for attachment piece	DIN 934 M10 galvanised hexagonal nut	1
33	160 A	Cable feed-through	PG 11	1
34	160 B	Silicone sheath for cable feed-through	66 x Ø10 x 1	3
35	160 K	Special-length connecting cable	H07 RN-F 3G 1.5 in compliance with VDE 0282T.810, black	1
	160 L	Standard 10-m connecting cable	H07 RN-F 3G 1.5 in compliance with VDE 0282T.810, black	1
36	160 C	Rubber seal for connecting cable	Ø 17 x 11	1
37	160 D	Clamping ring for connecting cable	Ø 17 x 12	2
38	160 E	Silicone sheath for cable connection	51 x Ø3 x 1	1
39	160 F	Strain relief	Gripper clamp	1
40	161	Connecting plug	Mennekes safety plug in compliance with DIN 49442/43 with bayonet ring	1
41	161 A	Protective cap	Mennekes protective cap in compliance with DIN EN 60309-2, protection class: IP67	1
42	161 B	Cable-restraining belt with clamp	460 x 25	1